

The BatteryMINDER charges and maintains any size 6 volt car, truck, tractor battery without ever overcharging.

The BatteryMINDER comes complete with a molded ring terminal assembly and insulated battery clips. The 18-gauge lamp wire for connecting multiple batteries is not provided in the package.

General

The BatteryMINDER Charger/Maintainer/Conditioner Model 12106 is designed to charge and maintain your battery without ever overcharging it. The unit utilizes patented technology to produce a wide range of high frequency pulses (RFP) designed to dissolve both old and newly formed sulphate. The pulses free the battery from sulphate and extend the life of your battery.

The 6 Volt - 1 Amp BatteryMINDER allows you to charge up to 4 batteries (parallel connected for 6 volt) at a time. The batteries must be the same type (starter, deep cycle, sealed gel, AGM, etc.). Also, the battery voltage (6 volt), the resting voltage (minimum of 5.5 volts for a 6 volt battery), Amp and the condition of the batteries must be the same if you charge more than one battery at the same time. See page 7 for more information on parallel and series connections.

Use the BatteryMINDER on your battery at all times (winter, summer, spring or fall) when your battery is not used for 4 days or more. This will prevent new sulphation from taking place and will lead to dramatically increased battery life and performance. Do not remove the BatteryMINDER from your battery unless you place the battery back in service.

Failure to keep the BatteryMINDER connected to your battery at all times that the battery is not in service will affect its performance claims.

BatteryMINDER Specifications

The BatteryMINDER is UL Listed and CSA Certified.

Input	105-130 Vac 50/60 Hz
Output	6 volts @ 1.0 Amps
Charge Voltage	7.2 Vdc
Float Voltage	6.5 Vdc
Desulphation Pulse	1.0A @ 3.26 MHz
Float Current	5 Ma - 200 Ma*
Size/Weight	3-1/4" L x 1-3/4" W x 2-1/4" H / 2 lbs

Battery Voltage vs. Charge Percentage

Hydrometer Reading on Each Cell	Voltage	Percentage
1.270	6.35 volts	100 %
1.250	6.25 volts	75 %
1.190	6.15 volts	50 %
1.150	6.05 volts	25 %
1.120	5.9 volts	0 %

Testing Your Battery

It is extremely important that you determine the health of your battery before you attempt to recharge and recondition it. If any of the cells are shorted (no reading on a hydrometer tester), or the difference in charge level is greater than 0.50 SG between any two cells (two ball difference if you use a ball-type hydrometer), your battery cannot be properly recharged and reconditioned. Discard the battery in an appropriate lawful manner.

The BatteryMINDER has no electrical output unless it is connected to a healthy battery. Testing the BatteryMINDER with a volt or an Amp meter without the unit being connected across a good battery will result in a false reading. If you experience any problems, or are not sure of how to properly use or connect your BatteryMINDER, please e-mail our technical support at techsupport@vdcelectronics.com or call our toll-free technical support line (800-379-5579 ET). Be certain to leave your phone number with the area code, time zone and the best time to call.

Testing a Manifold-type Lead Acid Battery

1. Carefully remove all 3 caps or both manifold-type covers from your battery
2. Check the water/electrolyte level. If the level is low or has ever been below top of plates, severe lead plate sulphation has taken place. Significant recharge/reconditioning time is needed to restore those plates to a condition where they can be expected to function normally.
3. Refill each cell with distilled water only to a level of ¼" minimum over the top of the cell's plates.
4. Recharge the battery with the BatteryMINDER to ensure that it is slowly and completely charged before you determine its condition.
5. If the BatteryMINDER does not start blinking within 72 hours, your battery may be too far gone to be reconditioned. However, lightly touch the desulphation

button to set the unit in the maintenance/desulphation mode. The light will blink continuously until it is disconnected from the battery.

6. Allow the battery to remain in the maintenance mode for a minimum of 72 hours before you test it for dead cells. Use a hot/cold calibrated hydrometer tester for the most accurate results. If you see an increase in the Specific Gravity (SG) indicating that there is an improvement in the battery's condition, continue desulphating for an additional 72 hours and retest the battery. Continue this process until the SG reading of the battery does not increase anymore.

Testing with a Hot/Cold Calibrated Hydrometer Tester

Read the tester instructions carefully for most accurate readings.

1. When using the tester the first time or after a long period of non-use, fill the tester with the battery fluid and let it sit for 1/2 hour or longer. This will soak the balls in order to give you more accurate readings. Failure to do so will give you false readings indicating a battery that may not be in as good a condition as you may have thought.
2. After inserting the tester in a cell, gently tap the tester several times against the inside wall of each cell to dislodge air bubbles that will cause more balls to float than should. Failure to do so will yield false readings that indicate a battery that is not fully desulphated or does not qualify for desulphation.
3. If no balls float in any cell, the cell is considered shorted. This means that your battery is beyond the point of being properly recharged or reconditioned.
4. Dispose of the battery.
5. If each cell floats two or more balls (or 1260 on gauge-type), your battery can be reconditioned.
6. Always rinse the tester with fresh water after every use. Failure to do so will cause false readings.
7. Store the tester in the holder to prevent breakage.

Testing a Sealed, Maintenance-free, Gelled-type Lead Acid Battery

These batteries have no filler caps or manifold-type covers. If you cannot gain access to the interior of your battery, because it is sealed, you cannot test it with a hydrometer.

1. Test the battery with a voltmeter. If the voltage is less than 5.5 volts, charge the battery overnight with a regular charger or with the BatteryMINDER.
2. Let the battery rest for minimum of 8 hours, which means that you do not use or charge the battery for 8 hours.
3. Test the battery with a voltmeter. If the voltage is less than 6.05 volts (25% charge), the battery might have too much sulphation in it to reach full charge.
4. Connect the BatteryMINDER to the battery.
5. Lightly touch the Desulphation button to start the maintenance/desulphation mode right away.
6. Let the BatteryMINDER desulphate the battery at least a week.
7. Test the battery again with a voltmeter.

Installing the BatteryMINDER

Before you connect the BatteryMINDER to your battery, test the battery for any shorted cells and check the voltage in the battery. The battery has to have a minimum resting voltage of 5.5 volts before the unit will turn on. Resting voltage means that the battery has not been charged or discharged within 8 hours minimum. If you test a battery that has not rested for at least 8 hours, you will get incorrect, inaccurate readings.

1. Test your battery first before you connect it to the BatteryMINDER. See page 2 for more information on testing the battery. See page 5 for more information about installing the BatteryMINDER inside or outside of the equipment.
2. Check the voltage in your battery. If the resting voltage is less than 5.5 volts, use a regular charger to charge the battery to full voltage before connecting the BatteryMINDER to it. The BatteryMINDER does not turn on if the voltage is lower than 5.5 volts.
3. Plug the battery clip assembly supplied in the box into the mating plug at the end of the BatteryMINDER's output cord, or attach the ring terminal assembly to your battery's terminals (red to + and blue to -).
4. Attach the battery clips to the posts or terminal clamps of the battery (red to + and black to -).
5. The green indicator lights when the proper connection is made. The green light is powered by the battery and lights up even when the BatteryMINDER is not plugged in an electrical outlet.
6. Plug the BatteryMINDER into an AC electrical outlet as soon as possible after you have made the connection to the battery. Note: The unit will use the power from your battery and drain the battery if you do not plug it into an electrical outlet.
7. The red indicator lights to show that there is AC power going into the unit. If the red light does not come on, check you outlet to make sure that it is switched on. The red light stays on unless the outlet is switched off or the BatteryMINDER has failed.
8. The BatteryMINDER charges your battery to full voltage first before it automatically goes into the maintenance/desulphation mode. The green light stays solid during the charging mode.
9. The green indicator light starts blinking automatically after the BatteryMINDER has charged the battery to full voltage and goes into the maintenance/desulphation mode. If there is a lot of sulphate in your battery, it cannot accept full charge, and the BatteryMINDER does not automatically start desulphating (the voltage in the battery has to go up to 7 volts).
10. If the green indicator does not start blinking within 24 hours, lightly touch the Desulphation button to manually start the maintenance mode.
11. Leave the BatteryMINDER connected to your battery at all times when it is not in actual use. You can never overdesulphate your battery.

See page 7 for more information about connecting multiple batteries.

Connecting the BatteryMINDER when Batteries are Installed in the Equipment

Follow these instructions when battery is installed in equipment (vehicle, PWC, boat, tractor, etc.). A spark near battery may cause battery to explode. To reduce risk of a spark near battery:

1. Position DC output cord to reduce risk of damage by hood, door, covers, or moving engine parts.
2. Stay clear of fan blades, belts, pulleys, and other parts that can cause injuries.
3. Check polarity of battery posts. The POSITIVE (POS, P, +) battery post usually has a larger diameter than the NEGATIVE (NEG, N, -) post.
4. Determine which post of battery is grounded (connected) to the chassis of equipment. If the negative post is grounded, see Item N. If the positive post is grounded, see Item P.
N. For negative grounded equipment, connect the POSITIVE (RED) clip from the charger to the POSITIVE (POS, P, +) ungrounded post of the battery. Connect the NEGATIVE (BLACK) clip to the vehicle chassis or the engine block away from the battery. Do not connect the clip to carburetor, fuel lines, or metal body parts.
P. For positive ground equipment, connect the NEGATIVE (BLACK) clip from the charger to the NEGATIVE (NEG, N, -) UNGROUNDED post of the battery. Connect the POSITIVE (RED) clip to chassis or engine block away from the battery. Do not connect the clip to carburetor, fuel lines, or sheet metal body parts. Connect to heavy gauge metal part of the frame or engine.
5. When disconnecting the charger, disconnect it from the AC outlet, and then remove the clips from the vehicle chassis, and the battery posts.

Connecting the BatteryMINDER when Batteries are Outside of Equipment

Follow these steps when battery is outside of vehicle or equipment. A spark near the battery may cause battery explosion. To reduce risk of a spark near battery:

1. Check the polarity of battery posts. The POSITIVE (POS,P,+) battery post usually has a larger diameter than the NEGATIVE (NEG, N, -) battery post.
2. Attach at least a 24 inch long 6-gauge (AG) insulated battery cable to the NEGATIVE (NEG -) battery post.
3. Connect the (RED) charger clip to (POS+) the post of the battery.
4. Position yourself and free end of cable as far away from battery as possible, and then connect the NEGATIVE (BLACK) charger clip to free end of the cable.
5. Do not face battery when making final connections.

6. When disconnecting the charger, always do so in reverse sequence of the connecting procedure, and break first connection while as far away from battery as is practical.
7. A marine (boat) battery must be removed and charged on shore. To charge it onboard requires equipment specifically designed for marine use.

Operating the BatteryMINDER

After you have installed the BatteryMINDER, keep it connected unless you are using the battery. The unit keeps desulphating and the green LED blinks until the unit is disconnected from the battery. Note: You cannot overdesulphate your battery.

Display	Operating Condition
Red Solid Light	The red indicator lights to show that there is AC power going into the unit.
Green Solid Light	When the unit is attached to your battery, the green solid light lets you know that the unit is charging your battery.
Green Blinking Light	The green blinking light lets you know that it is desulphating your battery. If there is a lot of sulphate in your battery, it cannot accept full charge, and the BatteryMINDER does not automatically start desulphating. The voltage in the battery has to go up to 7 volts in order for the unit to automatically start desulphating.

Desulphating Your Battery Manually

If there is a lot of sulphate in your battery, it cannot accept full charge, and the BatteryMINDER does not automatically start desulphating (the voltage in the battery has to go up to 7 volts). Your battery may not be able to be properly charged or conditioned. However, you might be able to save your battery by desulphating it first.

If you know that your battery cannot be charged to 7 volts because of sulphate build-up, you should start the desulphation mode manually to start desulphating the battery right away. Lightly touch the Desulphation button, and the green light starts blinking. Leave your battery connected to the BatteryMINDER for a minimum of one week before re-testing it. It could take anywhere from a few days to a couple of month to completely desulphate a battery.

Connecting and Maintaining Multiple Batteries

Before you start using your BatteryMINDER, check how your batteries are connected and decide how you are going to connect the batteries to the BatteryMINDER.

If the batteries are connected in your diesel truck, golf cart, RV or airplane in series, you have to use a series connection to the BatteryMINDER.

If your batteries are disconnected or removed from your vehicle, you may use a series or a parallel connection depending on the model of the BatteryMINDER and the voltage of the batteries.

Parallel-connected with a 6 Volt 1 Amp BatteryMINDER

Batteries of the same type only (engine starting, deep cycle, sealed, gelled, AGM, maintenance-free) can be charged at the same time in parallel (+ to +, - to -).

When you connect the batteries in parallel, you are keeping the total voltage the same. For example, if you connect two 6 volt batteries in parallel, the voltage of the combination is 6 volts.

When you connect multiple batteries in parallel, connect the + of the first battery to the + of the second battery. Then connect the - of the first battery to the - of the second battery. The + of the first battery and the - of the first battery connect to the BatteryMINDER if possible; otherwise, connect to the accessible battery.

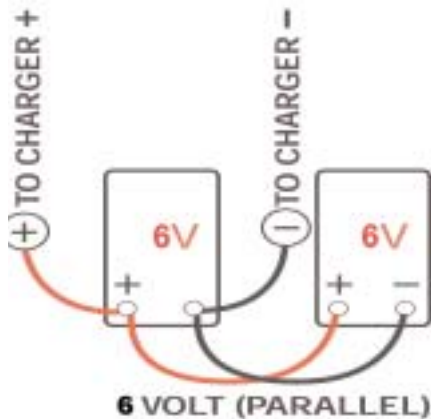

Connect each battery to one another using 18 gauge (lamp cord type) insulated wire. Strip at the points where you wish it to be in electrical contact with the posts of each battery, then use ring or clip connectors. VDC Electronics, Inc. does not provide any type of wire harness to accomplish this, due to the many variations in size and terminal configuration.

Always desulphate each battery separately for 2-3 days if they are connected in parallel. Otherwise, they will not be equally desulphated.

Troubleshooting

Problem	Solution
Red light is not on	If the red Indicator light does not come on when you plug the BatteryMINDER into an AC outlet, check that the outlet is switched on. If the light still does not come on, the BatteryMINDER might have failed.
Green light is not on	If the solid green indicator light does not come on, you have not made a proper connection to the battery. The green light lights up even before you have plugged the unit into an electrical outlet.
Green light is not blinking	If the green indicator light does not start blinking within 72 hours, the unit was not able to bring the battery to full voltage. The unit is designed to automatically go into the maintenance mode when it reached 7 volts. To start the maintenance mode manually, lightly touch the Desulphation button. Note that the failure to press the Desulphation button if the green light does not blink within 72 hours may lead to unit burn-out or battery damage and void your warranty.
I don't think that the BatteryMINDER is working properly	The BatteryMINDER will not start if the voltage in the battery is lower than 5.5 volts in a 6 volt battery. The lights will come on, though. Test it on your car battery. Green light should start blinking after a short period of time. Test the battery with a voltmeter. It should read around 7 volt DC when the BatteryMINDER is running. Also, the unit will feel warm to touch when it is working.

Underwriters Laboratory (UL) Required Safety Instructions

1. Do not expose charger to rain or snow. It is designed to operate ONLY INDOORS
2. Use of any attachment not specifically recommended by the battery charger manufacturer for use with this exact model of charger may result in risk of fire and electric shock or injury to person.
3. An extension cord should not be used, unless absolutely necessary. Use of an improper extension cord could result in fire or electric shock. If extension cord must be used be sure:
 - a) Pins on plug of extension cord are the same number, size, & shape of plug on charger.
 - b) Extension cord is properly wired and in good condition.
 - c) Wire size is large enough for AC ampere rating of charge as specified below: Length of cord, feet (meters) 25 (7.6) 60 (15.2) 100 (30.5) 150 (45.6) AWG Size 18.
4. Do not use charger if it received a sharp blow, been dropped, or damaged in any way.
5. Charger contains no serviceable parts. If it fails for any reason, return to the address shown within for a free replacement under warranty.
6. To reduce risk of electric shock, unplug charger from outlet before attempting any maintenance or cleaning.
7. **WARNING:** Risk of explosive gases. Whenever you work near a lead acid battery it is dangerous. Batteries generate explosive gases during normal battery operation. For this reason, it is of utmost importance that each time before using your charger, you read this manual and follow the instructions exactly. To reduce risk of battery explosion, follow these instructions and those published by the battery manufacturer and the manufacturer of any equipment you plan to use in the vicinity of the battery. Review cautionary markings on the products and the engine.
8. **PERSONAL PRECAUTIONS:** When working with/near a lead acid battery.
 - a) Someone should be in range of your voice or close enough to come to your aid when you work near a lead acid battery.
 - b) Have fresh water and soap nearby in case battery acid contact skin, clothing, or eyes.
 - c) Wear complete eye protection and clothing protection. Avoid touching eyes while working near battery.
 - d) If battery acid does contact skin or clothing, wash immediately with soap and water. If acid entered the eye, immediately flood the eye with running water for at least 10 minutes and get help immediately.
 - e) Never smoke or allow a spark of flame near battery or engine.
 - f) Be extra cautious to reduce risk of dropping a metal tool or auto part onto battery. It might spark or short circuit battery or other electrical part that may cause an explosion.

- g) Remove personal metal items such as rings, bracelets, necklaces, and watches when working with a lead acid battery. A lead acid battery can produce a short circuit current high enough to weld a ring or the like to metal, causing a severe burn.
- h) Charger is designed to be used for recharging lead acid batteries. Never use it to power a low voltage electrical system, or for attempting to recharge dry cell batteries that are commonly used in house holds. These batteries may explode and cause injury to persons and damage property.

Never charge a frozen battery or a battery at a temperature above 123° F.

- a) If necessary to remove battery from equipment to charge, always remove ground terminal first. Turn off all accessories in the vehicle, so as not to cause an arc.
- b) Be sure area around battery is well ventilated while battery is being charged. Gas vapors can be forcefully blown away by using a piece of non-metallic material as a fan.
- c) Clean battery terminals. Be careful to keep corrosion from contacting eyes.
- d) Add distilled water to each cell until battery acid reaches level specified by the manufacturer. This helps Purge excessive gas from cells. Do not overfill. For a battery with out cell caps, follow manufacturer's recharging instructions.
- e) Study all battery manufacturer's specific instructions such as removing cell caps while charging and recommended charge rates.
- f) Determine voltage of battery by referring to equipment owner's manual and make sure that charger output voltage is correct.

Charger Location

- a) Make sure charger is as far away from battery as output cables permit.
- b) Never place charger directly above battery being charged; gases from battery will corrode and damage charger.
- c) Never allow battery acid to drip on charger when reading specific gravity or filling.
- d) Do not operate charger in a closed-in area or restrict ventilation in any way.
- e) Do not set battery on top of charger.

DC Connection Precautions

- a) Connect and disconnect DC output clips only after removing charger from outlet.
- b) Never allow clips to touch each other.
- c) Attach clips to battery posts and twist or rock back and forth several times to make good contact. This keeps clips from slipping off terminals and reduces risk of sparking.

**ONE (1) YEAR 100% UNCONDITIONAL
MONEY BACK GUARANTEE:**

BatteryMINDer is guaranteed to perform as claimed, or we will refund your full purchase price including all taxes, shipping or handling cost applicable to the purchase. Unit must be returned with Proof of Purchase directly to VDC Electronics, Inc., not to the dealer from which it was purchased. Physical damage to the unit will limit this guarantee.

5-YEAR LIMITED WARRANTY

VDC Electronics, Inc. warrants this product for FIVE (5) years from date of purchase at retail against defective materials or workmanship. It will be repaired or replaced at no charge providing it is returned to VDC Electronics, Inc., freight prepaid together with Proof of Purchase. We make no warranty other than this limited warranty and expressly exclude any implied warranty including any warranty for consequential damages. (This limited warranty is not transferable.)

Return unit to:
VDC Electronics, Inc., 83 Cedar Lane, P.O. Box 5537
Englewood, NJ 07631-5537